

- 4) SHELL: 4-22-04 PROOF TEST.  
3) EXTEND ALL CPLGS. 5/8" INSIDE.  
2) HYDRO @ 240 PSIG. MIN.  
NOTE: 1) SEAL ALL OPENINGS TO KEEP CEMENT MOIST TO PREVENT CRACKING.

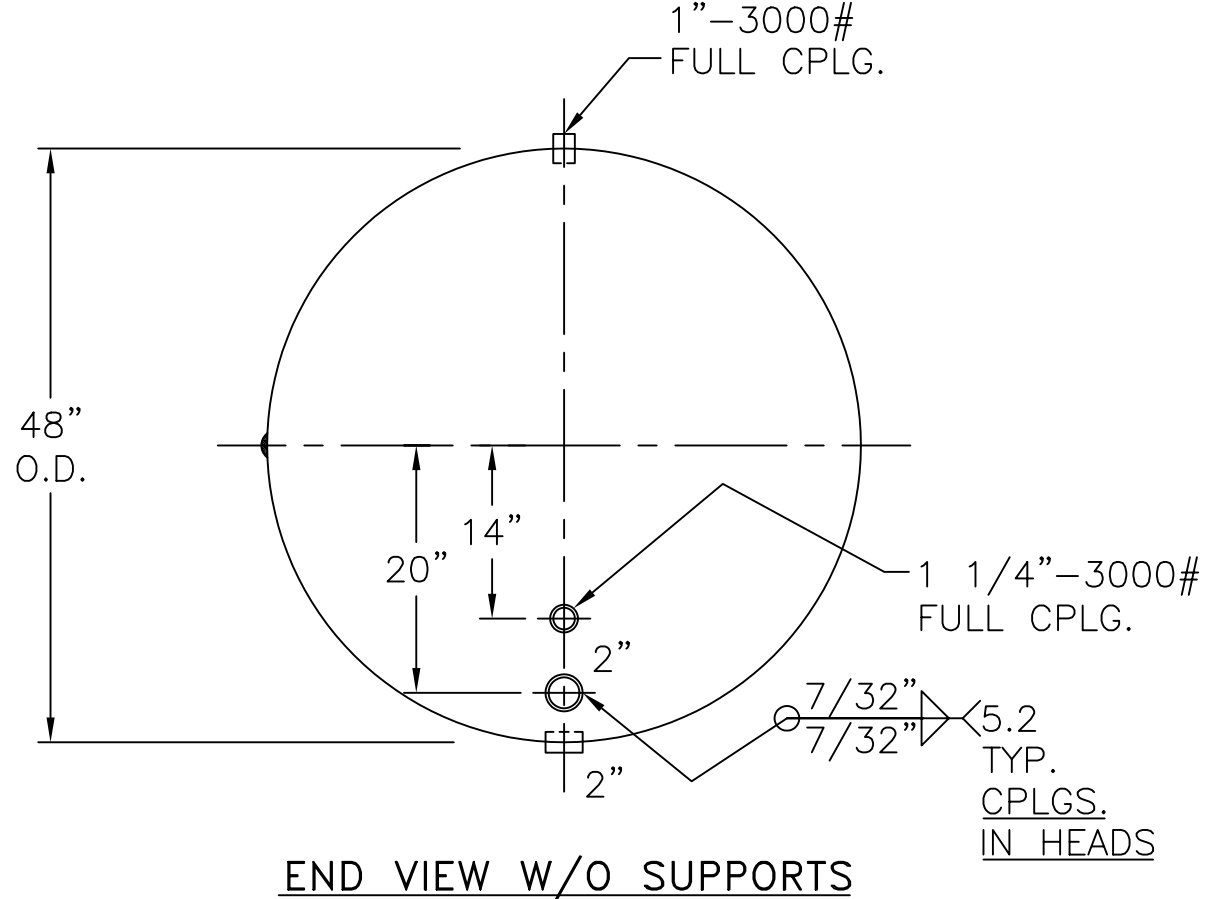

HEADS	.245" SA-455 2:1 S.E.	CS-48-1080-H	REV. 9-17-04
	(.230" MIN.) JOGGLE		DATE: 10-3-89
SHELL	.200" SA-455	FOR: HANSON STANDARD	
		HORIZ. HOT WATER TANK	
M.A.W.P. 160 PSIG. @ 210 °F		162.1 SQ. FT. SURFACE AREA. THIS TANK IS SHIPPED WITH ALL OPENINGS SEALED. THE CEMENT LINING MUST BE KEPT MOIST BEFORE, DURING, AND AFTER INSTALLATION TO PREVENT CRACKING OF THE CEMENT.	
ASME. SECTION IV 2001 ADD 2003		INSIDE: CEMENT LINED (1036)	
X-RAY: RT-NO / H.L.W.		OUTSIDE: PRIME	
GALLONS: 1080 WT. 2778 LBS.		CAD-"B" UNDER "STD"-SERIES	
SERIAL NO.		BY: E.S.	SCALE: 3/4"=12"
N.B.		<b>ROY E. HANSON JR. MFG.</b>	
		1924 COMPTON AVE. LOS ANGELES, CA 90011	